



swiss lifting solutions

TECHNICAL DATA
ELECTRIC CHAIN HOISTS
GPM250 AND GP250/500/1000
+ TROLLEYS





General information

General information	03
---------------------	----

Combinations

Combination electric chain hoist + trolley	03
--	----

Performance data

Electric chain hoists GPM and GP 3-Ph	04 - 05
Trolleys GHF, EHF and EMFE 3-Ph	06 - 07
Electric chain hoists GPM, GP and electric trolleys EMFE 1-Ph	08 - 09

Dimensions

Electric chain hoists	10
Trolleys	11

General information

GIS - electric chain hoists are used everywhere, where process safety of lifting systems is important: in the hard three-shift operations in automotive and other high production industries, in dusty or chemical aggressive environments, for outdoor use, for the entertainment industry or for extreme lifting heights in wind power plants. GIS - electric chain hoists and trolleys are made to high standards.

The safety factor of the load chain is at least 8 (1-fall in FEM 2m, ISO 5M) which reduces wear and tear and increases the service life.

GIS electric chain hoists have been developed and manufactured in Switzerland for more than 50 years.

For many industrial lifting applications standard GIS electric chain hoists offer the ideal solution. Depending on the complexity of the task and the conditions on site we offer GIS special products. A wide range of accessories and options is available.

GIS - electric chain hoists and trolleys are designed according to the latest EC directives.

The values listed in the tables are approximate values. Differences due to technical modifications are always possible and subject to change.

Combination electric chain hoist + trolley

The table below helps you to select the ideal combination of electric chain hoist and trolley.

Type	GHF500K	EHF/EMFE50						EHF/EMFE150				EHF/EMFE300			EHF/EMFE500				GISKB		
	500	1000						2000				4000			5000				GISKB III	GISKB III/IV	GISKB Alu
Flange width (mm):	50 - 99 100 - 149	50 - 99	100 - 149	150 - 199	200 - 240	241 - 300	76 - 139	140 - 199	200 - 259	260 - 320	56 - 119	120 - 179	180 - 239	240 - 300	56 - 119	120 - 179	180 - 239	240 - 300	GISKB III	GISKB III/IV	GISKB Alu
GPM250 with eyebolt suspension	✓	✓	x	x	x	x	x	x	x	x	x	x	x	x	x	x	x	x	✓	x	✓
with hook suspension	✓	✓	x	x	x	x	x	x	x	x	x	x	x	x	x	x	x	x	✓	x	x
GP250 with eyebolt suspension	✓	✓	✓	✓	✓	✓	✓	✓	x	x	x	x	x	x	x	x	x	x	✓	○	✓
with hook suspension	✓	✓	✓	✓	✓	✓	x	x	x	x	x	x	x	x	x	x	x	x	x	✓	x
GP500 with eyebolt suspension	✓	✓	✓	✓	✓	✓	✓	✓	x	x	x	x	x	x	x	x	x	x	✓	○	✓
with hook suspension	✓	✓	✓	✓	✓	✓	x	x	x	x	x	x	x	x	x	x	x	x	x	✓	x
GP1000 with eyebolt suspension	x	x	x	x	x	x	✓	✓	✓	✓	x	x	x	x	x	x	x	x	✓	○	x
with hook suspension	x	x	x	x	x	x	✓	✓	✓	✓	x	x	x	x	x	x	x	x	x	x	x
with suspension part	x	x	x	x	x	x	x	x	x	x	✓	✓	✓	✓	✓	✓	✓	✓	x	x	x

○ = special eyebolt suspension for GISKB III/IV

Electric chain hoists GPM250 and GP250/500/1000



The GP is simple in its structure and does not contain any sensitive electronics, which minimises the risk of operational interruptions. It is characterised by quiet running and is made for longevity whilst working hard. The ergonomic control switch with 42 V low voltage allows convenient and safe working. Maintenance is easy, quick and needs no special tools.

Scope of supply

Electric chain hoist with eyebolt suspension, geared limit switch for highest and lowest hook position, chain bucket, 2-button control switch with emergency-stop, standard lifting height 3 m, control cable length 1.8 m

Classification ISO (FEM) Type	M3 (1Bm) 150 s/h, 25 % duty	M4 (1Am) 180 s/h, 30 % duty	M5 (2m) 240 s/h, 40 % duty	M6 (3m) 300 s/h, 50 % duty	M7 (4m) 360 s/h, 60 % duty	M7 (4m) 360 s/h, 60 % duty	Speed 50 Hz (m/min)	Speed 60 Hz (m/min)
	Load capacity (kg)							
GPM250/1NF	-	320	250	200	-	-	8/2	9.6/2.4
GPM250/1SF	-	-	125	100	-	-	16/4	19.2/4.8
GP250/1N	400	320	250	200	160	125	8	9.6
GP250/1NF	400	320	250	200	160	125	8/2	9.6/2.4
GP250/1SF	-	160	125	100	-	-	16/4	19.2/4.8
GP250/2N	-	630	500	400	320	250	4	4.8
GP250/2NF	-	630	500	400	320	250	4/1	4.8/1.2
GP500/1N	800	630	500	400	320	250	8	9.6
GP500/1NF	800	630	500	400	320	250	8/2	9.6/2.4
GP500/1SF	-	320	250	200	160	125	16/4	19.2/4.8
GP500/2N	-	1250	1000	800	630	500	4	4.8
GP500/2NF	-	1250	1000	800	630	500	4/1	4.8/1.2
GP1000/1N	1600	1250	1000	800	630	500	8	9.6
GP1000/1NF	1600	1250	1000	800	630	500	8/2	9.6/2.4
GP1000/1SF	-	630	500	400	320	250	16/4	19.2/4.8
GP1000/2N	-	2500	2000	1600	1250	1000	4	4.8
GP1000/2NF	-	2500	2000	1600	1250	1000	4/1	4.8/1.2

- Standard voltages: 3ph 230, 460 and 575 V / 60 Hz
- 110 V low voltage control
- Profile steel chain according to EN818-7, case hardened and manganese phosphated
- Load hook according to DIN 15401, 360° rotatable
- Insulation class: F
- Area of application: -15° to +50°C
- Utilisation period 1600 h (ISO 4301-1:D, M5)



GPM250, GP250/500/1000 3-Ph
Lifting capacity up to 2500 kg

Model Type	Motor power (kW)	Number of chain falls	Chain diameter (mm)	Chain weight per meter (kg)	Protection class	Weight unequipped (kg)	Weight equipped, 3 m lifting height (kg)	Sound pressure level, in hall, 1 m distance (dBA)	Fuse protection (A)
GPM250/1NF	0.37/0.1	1	3.75x10.75	0.34	IP65	14	17	65	10
GPM250/1SF	0.37/0.1	1	3.75x10.75	0.34	IP65	14	17	65	10
GP250/1N	0.72	1	3.75x10.75	0.34	IP65	22	24	70	10
GP250/1NF	0.72/0.18	1	3.75x10.75	0.34	IP65	22	24	70	10
GP250/1SF	0.72/0.18	1	3.75x10.75	0.34	IP65	22	24	70	10
GP250/2N	0.72	2	3.75x10.75	0.34	IP65	22	25	70	10
GP250/2NF	0.72/0.18	2	3.75x10.75	0.34	IP65	22	25	70	10
GP500/1N	0.72	1	5.25x15	0.69	IP65	23	26	70	10
GP500/1NF	0.72/0.18	1	5.25x15	0.69	IP65	23	26	70	10
GP500/1SF	0.72/0.18	1	5.25x15	0.69	IP65	23	26	70	10
GP500/2N	0.72	2	5.25x15	0.69	IP65	23	28	70	10
GP500/2NF	0.72/0.18	2	5.25x15	0.69	IP65	23	28	70	10
GP1000/1N	2.3	1	7.45x23	1.37	IP65	49	57	80	10
GP1000/1NF	2.3/0.68	1	7.45x23	1.37	IP65	50	58	80	10
GP1000/1SF	2.3/0.68	1	7.45x23	1.37	IP65	50	58	80	10
GP1000/2N	2.3	2	7.45x23	1.37	IP65	49	61	80	10
GP1000/2NF	2.3/0.68	2	7.45x23	1.37	IP65	50	62	80	10

Trolleys GHF500, EHF50 - 500 and EMFE50 - 500



GIS trolleys are simple in design and allow smooth transportation of loads up to 5000 kg on steel beams. The electric chain hoist serves as a lifting device. The travel movement, tailored to the load capacity and the local conditions is either manually or electrically driven. The integrated fall and climbing protection ensures maximum safety. Due to their good handling characteristics and their longevity, GIS trolleys are often used by our customers as components for endcarriages of underslung travelling cranes.

Scope of supply

Push trolley GHF and EHF consisting of 2 side plates, support bolt(s)

Electric trolley EMFE consisting of 2 side plates, support bolt(s), counterweight, DC-spring loaded brake, connection cable to hoist, 4-button control switch with emergency stop control cable length depending on lifting height

Classification ISO (FEM) Type	M3 (1Bm)	M4 (1Am)	M5 (2m)	M6 (3m)	M7 (4m)	Speed 50 Hz (m/min)	Speed 60 Hz (m/min)
	150 s/h, 25 % duty	180 s/h, 30 % duty	240 s/h, 40 % duty	300 s/h, 50 % duty	360 s/h, 60 % duty		
GHF500	500	500	500	400	320	-	-
EHF50	1000	800	630	630	500	-	-
EMFE50/N	1000	800	630	630	500	12	14.4
EMFE50/NF	1000	800	630	630	500	12/4	14.4/4.8
EMFE50/SF	800	800	630	630	500	20/6	24/7.2
EMFE50/N FU	1000	800	630	630	500	2-20	2-20
EHF150	2000	2000	1600	1600	1250	-	-
EMFE150/N	2000	2000	1600	1600	1250	12	14.4
EMFE150/NF	2000	2000	1600	1600	1250	12/4	14.4/4.8
EMFE150/SF	1600	1600	1600	1600	1250	20/6	24/7.2
EMFE150/N FU	2000	2000	1600	1600	1250	2-20	2-20
EHF300	4000	4000	3200	2500	2500	-	-
EMFE300/N	4000	4000	3200	2500	2500	12	14.4
EMFE300/NF	4000	4000	3200	2500	2500	12/4	14.4/4.8
EMFE300/SF	3200	3200	3200	2500	2500	20/6	24/7.2
EMFE300/N FU	4000	4000	3200	2500	2500	2-20	2-20
EHF500	5000	4000	3200	3200	2500	-	-
EMFE500/N	5000	4000	3200	3200	2500	12	14.4
EMFE500/NF	5000	4000	3200	3200	2500	12/4	14.4/4.8
EMFE500/SF	4000	4000	3200	3200	2500	20/6	24/7.2
EMFE500/N FU	5000	4000	3200	3200	2500	2-20	2-20

- Standard voltages: 3 × 400 V / 50 Hz, 3 × 230 V / 50 Hz
- 42 V low voltage control
- Side plates and load wheels made of cast iron (EHF and EMFE)
Side plates made of die-cast aluminium and load wheels made of glass fibre reinforced plastic (GHF)
- Support bolts zinc-plated
- Fall and climbing protection



GHF500
Lifting capacity up to 500 kg



EHF50 – 500
Lifting capacity up to 5000 kg

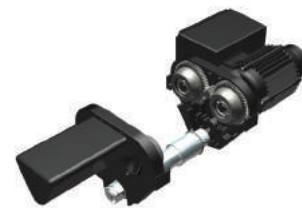

EMFE50 – 500 3-Ph
Lifting capacity up to 5000 kg

Model Type	Motor power (kW)	Protection class	Weight, for standard flange width (kg)	Minimum flange width (mm)	Maximum flange width (mm)	Minimum curve radius (mm)	Maximum flange thickness (mm)
GHF500	-	-	2.5	50	149	1200	24
EHF50	-	-	7.5	50	240	1200	24
EMFE50/N	0.25	IP55	27	50	240	1200	24
EMFE50/NF	0.15/0.045	IP55	27	50	240	1200	24
EMFE50/SF	0.15/0.045	IP55	27	50	240	1200	24
EMFE50/N FU	0.25	IP55	27	50	240	1200	24
EHF150	-	-	13.5	76	320	1500	27
EMFE150/N	0.25	IP55	31	76	320	1500	27
EMFE150/NF	0.15/0.045	IP55	31	76	320	1500	27
EMFE150/SF	0.15/0.045	IP55	31	76	320	1500	27
EMFE150/N FU	0.25	IP55	31	76	320	1500	27
EHF300	-	-	27.5	56	300	1800	30
EMFE300/N	0.25	IP55	50	56	300	1800	30
EMFE300/NF	0.15/0.045	IP55	50	56	300	1800	30
EMFE300/SF	0.15/0.045	IP55	50	56	300	1800	30
EMFE300/N FU	0.25	IP55	50	56	300	1800	30
EHF500	-	-	27.5	56	300	1800	30
EMFE500/N	2x0.25	IP55	57	56	300	1800	30
EMFE500/NF	2x0.15/0.045	IP55	57	56	300	1800	30
EMFE500/SF	2x0.15/0.045	IP55	57	56	300	1800	30
EMFE500/N FU	2x0.25	IP55	57	56	300	1800	30

Electric chain hoists GPM250 and GP250/500



The GPM and GP hoists are available in a 1-phase version destined for workshop use in the absence of 3-phase power supply, for mobile or outdoor use.

Scope of supply

Electric chain hoist with eyebolt suspension, chain bucket, 2-button control switch with emergency-stop, without geared limit switch for highest and lowest hook position, control cable length depending on lifting height

Classification ISO (FEM) Type	M3 (1Bm)	M4 (1Am)	M5 (2m)	M5 (2m)	M5 (2m)	M5 (2m)	Speed 50 Hz (m/min)	Speed 60 Hz (m/min)
	150 s/h, 25 % duty	180 s/h, 30 % duty	240 s/h, 40 % duty	240 s/h, 40 % duty	240 s/h, 40 % duty	240 s/h, 40 % duty		
			Load capacity (kg)					
GPM250/1N1Ph	-	-	125	100	80	-	8	9.6
GPM250/1NL1Ph	-	-	250	200	160	125	4	4.8
GP250/1N1Ph	-	-	250	200	160	125	8	9.6
GP250/1NL1Ph	-	-	250	250	160	125	4	4.8
GP250/2N1Ph	-	-	500	400	320	250	4	4.8
GP250/2NL1Ph	-	-	500	400	320	250	2	2.4
GP500/1N1Ph	-	-	250	200	160	125	8	9.6
GP500/1NL1Ph	-	-	500	400	320	250	4	4.8
GP500/2N1Ph	-	-	500	400	320	250	4	4.8
GP500/2NL1Ph	-	-	1000	800	630	500	2	2.4

Electric trolleys EMFE50 - 150



The electric trolleys EMFE are available in a 1-phase version destined for workshop use in the absence of 3-phase power supply.

Scope of supply

Electric trolley EMFE consisting of 2 side plates, support bolt(s), counterweight, DC-spring loaded brake, connection cable to hoist and 4-button control switch with emergency stop

Classification ISO (FEM) Type	M3 (1Bm)	M4 (1Am)	M5 (2m)	M6 (3m)	M7 (4m)	Speed 50 Hz (m/min)	Speed 60 Hz (m/min)
	150 s/h, 25 % duty	180 s/h, 30 % duty	240 s/h, 40 % duty	300 s/h, 50 % duty	360 s/h, 60 % duty		
			Load capacity (kg)				
EMFE50/N 1Ph	1000	-	-	-	-	12	14.4
EMFE150/N 1Ph	2000	-	-	-	-	12	14.4

- Standard voltages: 1 ph x 115 V / 60 Hz
- 110 V or 230 V control voltage (GPM250)
42 V low voltage control (GP250/500)
- Profile steel chain according to EN818-7, case hardened and manganese phosphated
- Load hook according to DIN 15401, 360° rotatable
- Insulation class: F
- Area of application: -15° to +50°C
- Utilisation period 1600 h (ISO 4301-1:D, M5)



GPM250, GP250/500 1-Ph
Lifting capacity up to 1000 kg

Motor power (kW)	Number of chain falls	Chain diameter (mm)	Chain weight per meter (kg)	Protection class	Weight unequipped (kg)	Weight equipped, 3 m lifting height (kg)	Sound pressure level, in hall, 1 m distance (dBA)	Fuse protection (A)
0.25	1	3.75x10.75	0.34	IP65	14	17	83	10
0.25	1	3.75x10.75	0.34	IP65	14	17	83	10
0.55	1	3.75x10.75	0.34	IP65	22	24	76	10
0.55	1	3.75x10.75	0.34	IP65	22	24	76	10
0.55	2	3.75x10.75	0.34	IP65	22	25	76	10
0.55	2	3.75x10.75	0.34	IP65	22	25	76	10
0.55	1	5.25x15	0.69	IP65	23	26	76	10
0.55	1	5.25x15	0.69	IP65	23	26	76	10
0.55	2	5.25x15	0.69	IP65	23	28	76	10
0.55	2	5.25x15	0.69	IP65	23	28	76	10

- Standard voltages: 1 × 230 V / 50 Hz, 1 × 115 V / 50 Hz
- 42 V low voltage control
- Side plates and load wheels made of cast iron
- Support bolts zinc-plated
- Fall and climbing protection

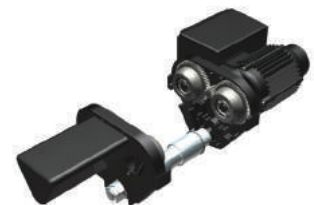

EMFE50 –1 50 1-Ph
Lifting capacity up to 2000 kg

Motor power (kW)	Protection class	Weight, for standard flange width (kg)	Minimum flange width (mm)	Maximum flange width (mm)	Minimum curve radius (mm)	Maximum flange thickness (mm)
0.25	IP55	27	50	240	1200	24
0.25	IP55	31	76	320	1500	24

Dimensions electric chain hoists

Type	a1 (mm)	a2* (mm)	a3* (mm)	a4 (mm)	b1 (mm)	b2* (mm)	b3 (mm)	c1 (mm)	c2 eye (mm)	c2 hook (mm)	c3 eye* (mm)	c3 hook* (mm)	h1 eye (mm)	h1 hook (mm)	Schematic drawing
GPM250/1	202	243	122	Ø30	389	120	20	134	39	90	419	470	330	381	9500.9201.5
GP250/1	246	296	151	Ø40	444	155	24	162	49	124	462	537	406	480	9510.9201.5
GP250/2	246	296	168	Ø40	444	155	24	162	49	124	462	537	432	506	9510.9202.5
GP500/1	246	296	151	Ø40	444	155	24	162	49	124	462	537	414	488	9511.9201.5
GP500/2	246	296	175	Ø40	444	155	24	162	49	124	462	537	453	528	9511.9202.5
GP1000/1	328	385	198	Ø52	548	180	33	212	58	132	598	672	519	593	9515.9201.5
GP1000/2	328	385	235	Ø52	548	180	33	212	58	132	598	672	578	652	9515.9202.5

*Chain bucket for lifting height 3 m

GP250, GP250/500/1000, 1-fall

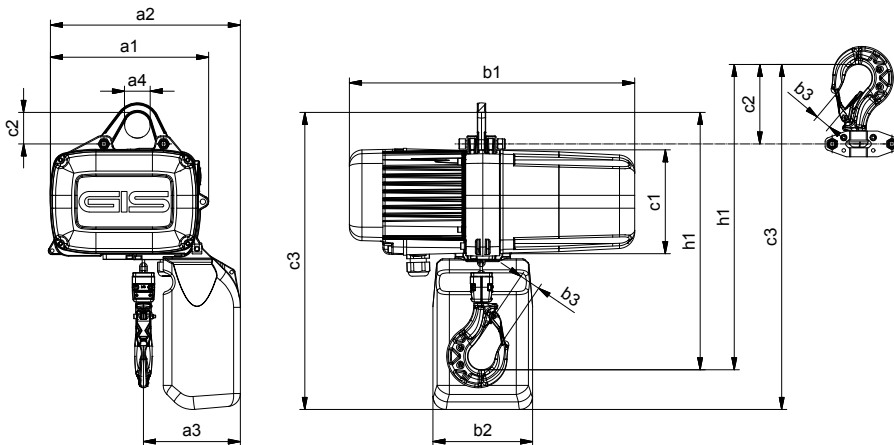

GP250/500/1000, 2-falls

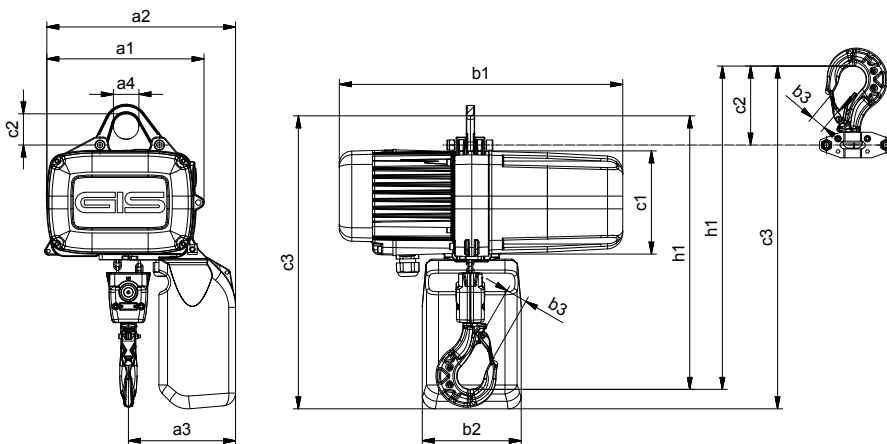

Dimensions trolleys

Type	e1 (mm)	e2 (mm)	f1 (mm)	f2 (mm)	f3 (mm)	f4 (mm)	f5 (mm)	f6 (mm)	g1 (mm)	g2 (mm)	h2 (mm)	Flange width (mm)	Schematic drawing			
GPM250/1 GP250/1 GP250/2 GP500/1																
GHF500	215	-	-	-	-	183	64	-	48	122	378	454	480	462	50 - 99	9248.9251.3
GP250/1 GP250/2 GP500/1 GP500/2																
EHF50	215	-	-	-	-	183	23	-	49	167	455	481	463	502	50 - 99	9248.9200.5
EMFE50	215	62	209	250	241	183	23	-	49	167	455	481	463	502	50 - 99	9248.9217.5
GP1000/1 GP1000/2																
EHF150	250	-	-	-	-	230	27	-	60	203	595	655			76 - 139	9248.9202.5
EMFE150	250	43	211	253	242	230	27	-	60	203	595	655			76 - 139	9248.9218.5
GCH1600/1 GCH1600/2 GCH2000/1 GCH2000/2																
EHF300	311	-	-	-	-	290	31	-	55	218	637	719	637	719	120 - 179	9248.9204.5
EMFE300	311	12	217	259	249	290	31	-	55	218	637	719	637	719	120 - 179	9248.9219.5
GCH2500/1 GCH2500/2																
EHF500	311	-	-	-	-	290	31	-	55	218	637	719			120 - 179	9248.9204.5
EMFE500	311	12	-	259	249	290	31	249	55	218	637	719			120 - 179	9248.9220.5

GHF500

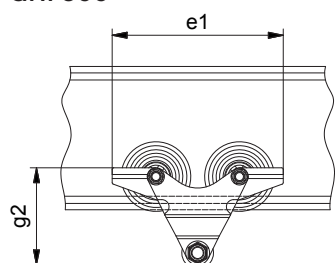

GHF500

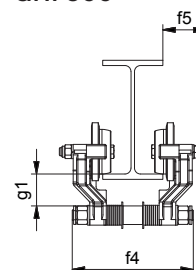

EHF50/150

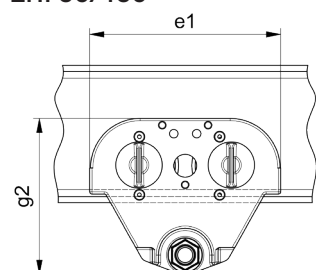

EHF300/500

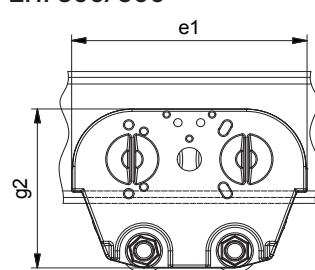

EHF50 - 500

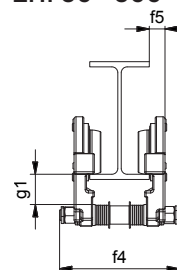

EMFE50/150

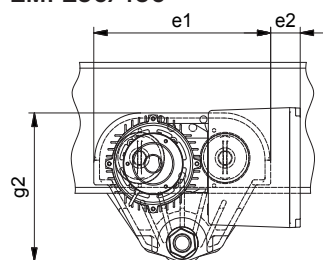

EMFE300/500

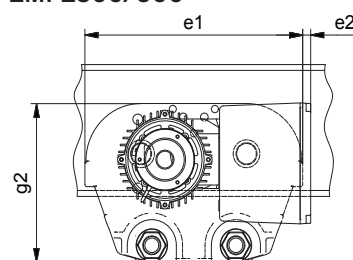

EMFE50 - 500

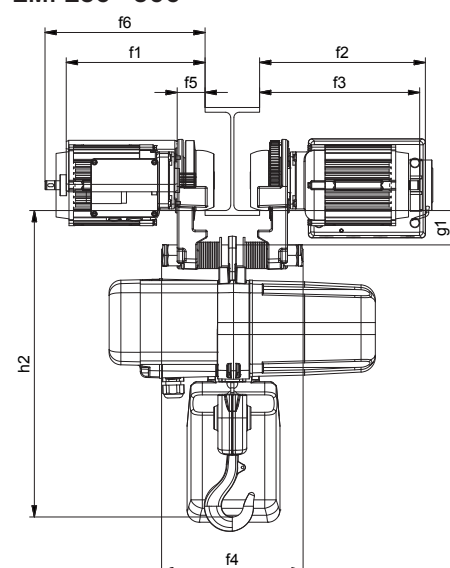



Crane systems

GISKB steel crane construction kit for line-bound or all-round goods handling. GISKB aluminium crane system, slewing pillar and wall cranes for smooth handling of transport goods. Travelling cranes and slewing cranes made of steel profiles for heavier loads.

Hoisting equipment

Over 50 years experience in the manufacture of electric chain hoists: robust, durable, reliable and highly resistant to wear. Simple maintenance. Various special versions for every application area. Wide range of accessories and options.

Vacuum handling systems

GIS vacuum handling systems for the ergonomic and gentle handling of goods made of different materials like wood, glass, stone, metal or plastic. In combination with the appropriate crane system.

GIS AG – the specialist for crane systems Founding of the GIS AG in 1957 | With own subsidiary in Germany since 1966 | Development and production of electric chain hoists in Switzerland for over 50 years | Swiss manufacturer of complete crane systems inc. hoisting equipment and vacuum lifters | Certified to ISO 9001 since 1994 | Complete market services from project planning to installation, start-up and maintenance | International sales network with over 50 qualified partners worldwide

AUTHORIZED DEALER



TEL [604] 796-9221
FAX [604] 796-9227
EMAIL INTEGRITY@HYDRAMACHCRANE.COM

WWW.HYDRAMACHCRANE.COM

