

# GIS

swiss lifting solutions

## INSTRUCTION MANUAL ELECTRIC CHAIN HOIST TYPE GPM 250



[www.gis-ag.ch](http://www.gis-ag.ch)



## Table of contents

<b>0</b>	<b>General instructions</b>	<b>4</b>
0.1	General safety instructions	4
0.1.1	Safety and hazard information	4
0.2	General safety regulations and organisational measures	4
0.2.1	Warning markings / Legends / Warning signs	4
0.3	Particular safety instructions	4
0.4	Instructions for hazard protection	5
0.4.1	Hazards - Mechanical	5
0.4.2	Hazards - Electrical	5
0.4.3	Sound pressure level	6
0.5	Technical status	6
0.5.1	Technical data	6
0.5.2	Periodic checks	6
0.5.3	Warranty	7
0.6	Intended use	7
0.6.1	Instructions for using the instruction manual	7
<b>1</b>	<b>Description</b>	<b>8</b>
1.1	Operating conditions	8
1.2	General description	9
1.3	Special models	10
<b>2</b>	<b>Start-up</b>	<b>10</b>
2.1	Transport and assembling	11
2.2	Connecting	11
2.2.1	Electrical connection	11
2.2.2	Load chain	12
2.2.3	Limit switch	13
2.2.4	Chain container	13
<b>3</b>	<b>Care and maintenance</b>	<b>13</b>
3.1	General guidelines for maintenance and servicing	13
3.2	Care and maintenance	14
3.2.1	Care overview	14
3.2.2	Maintenance overview	14
3.2.3	Braking system	14
3.2.4	Load chain	15
3.2.5	Limit stop	15
3.2.6	Gearing	15
3.2.7	Slipping clutch	15
3.2.8	Suspension parts	16
3.3	Ordering spare parts	16
<b>4</b>	<b>Measures for achieving safe operating periods</b>	<b>16</b>
4.1	Determining the actual period of use S	16
4.2	General overhaul	16
<b>5</b>	<b>Appendix</b>	<b>17</b>
5.1	Technical data	17
5.2	Electrical parameters	17
5.3	EC Declaration of conformity	18
5.4	EC Declaration of incorporation	19

## Spare parts / Ordering spare parts

The correct order numbers for original spare parts can be obtained from the relevant spare parts list. Please ensure that you have the following data on your chain hoist to hand. This will enable the correct spare parts to be supplied without delay.

Electric chain hoist type : .....

Serial number : .....

Year of manufacture : .....

Load capacity : .....

Original spare parts for the electric chain hoists can be acquired from the following addresses:

### 1. Manufacturer

GIS AG  
Swiss Lifting Solutions  
Luzernerstrasse 50  
CH-6247 Schötz

Tel. +41 (0)41 984 11 33  
Fax +41 (0)41 984 11 44

tel@gis-ag.ch  
www.gis-ag.ch

### 2. Resellers / Agent

.....

.....

.....

.....

.....

.....

.....

.....

.....

.....

.....

.....

## 0 General instructions

### 0.1 General safety instructions

#### 0.1.1 Safety and hazard information

The following symbols and terms are used in this instruction manual for safety and hazard instructions:



#### **DANGER !**

Non-compliance, either in part or full, with operating instructions with this symbol can result in serious personal injury or fatal accidents.

Warning information must be **strictly** adhered to.



#### **CAUTION !**

Non-compliance, either in part or full, with operating instructions with this symbol can result in major damage to machinery, property or material.

Information in the category "Caution" is to be **exactly** adhered to.



#### **NOTE**

Following the instructions marked with this symbol will lead to more effective and straightforward operation.

"Note" directions make work easier.

### 0.2 General safety regulations and organisational measures

The instruction manual for the electric chain hoist must always be available within the operating area of the hoist. The instructions mentioned in this manual must be strictly adhered to. Furthermore, supplementary to the instruction manual, the statutory regulations governing general accident prevention and environmental protection are to be enforced.

Operating and service personnel must have read and understood the instruction manual, in particular the safety instructions, before commencing work. Protective equipment must be made available for operating and service personnel and worn at all times. The operator or his representative is responsible for supervising operating personnel and ensuring they are aware of the hazards and safety implications of working with the electric hoist.

The manufacturer reserves the right to make technical changes to the product or changes to these instructions and assumes no liability for the completeness and up-to-dateness of these instructions. The original version of these instructions is in the German language. In case of doubt, the original German original version is exclusively valid as a reference document.

#### 0.2.1 Warning markings / Legends / Warning signs

- Oil chain.....figure 0-1
- CE sign.....figure 0-2
- Type plate.....figure 0-3
- Data plate.....figure 0-4
- Voltage.....figure 0-5

Figure 0-1

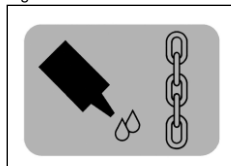

Figure 0-2



Figure 0-3

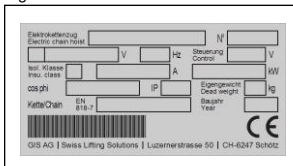
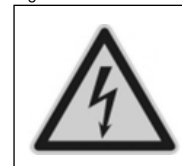

Figure 0-4

Typ	50 Hz m/min	ISO 4301/1			LastLoad t (m/min)		
		M4	M5	M6	M7	M8	M9
NF		30 %	40 %	50 %	60 %	80 %	
SF							
NL 1Ph							
N 1Ph							

Figure 0-5



### 0.3 Particular safety instructions

#### **Transport and assembly:**

- Electric chain hoists, single parts and large components should be carefully fixed to suitable and technically acceptable hoisting apparatus / load lifting members

#### **Electrical connection:**

- Connection work is only to be performed by personnel specifically designated and trained for the job

#### **Start-up / operation:**

- Before initial start-up, as well as daily start-up, carry out a visual check and carry out the predefined user-checks routine
- Only operate the electric chain hoist if the protective and safety equipment provided is ready and working
- Damage to the electric chain hoist and changes in its operational characteristics must be reported immediately to the responsible person
- After use, or when in a non-operational mode, the chain hoist should be secured against unauthorised and unintentional use
- Refrain from hazardous procedures

See also operational parameters (chapter 0.6).

**Cleaning / service / repair / maintenance / refitting:**

- Use working platforms provided for assembly work at high level
- Check electrical cables for damage or wear
- Ensure any oils or other agents used are collected and disposed of safely and in an environmentally sound manner
- Reassemble and check safety installations that have been disassembled for servicing or repairing the hoist once service and repair work has been completed
- Adhere to predefined testing and service intervals specified in the instruction manual
- Follow the directions in the instruction manual regarding exchanging parts
- Operating personnel should be informed before commencing special or refitting work
- Secure the repair working area
- Prevent the electric chain hoist from being unexpectedly switched on during service or repair work
- Erect warning signs
- Disconnect the power cable and ensure it cannot be switched on again by unauthorized personnel
- Retighten screw connections that have been loosened for repair or service work
- Replace non-reusable fixing elements and seals (e.g. self-locking nuts, washers, cotter pins, O-rings and seals)

**Shut down / storage:**

- Clean and preserve (lubricate/grease) the chain hoist before long periods of inactivity or storage

## 0.4 Instructions for hazard protection

Hazardous areas must be clearly marked by warning signs and cordoned off. It must be ensured that warnings regarding hazardous areas are given due attention.

**Hazards can stem from:**

- incorrect application
- not following safety directions properly
- not carrying out test and service work thoroughly

### 0.4.1 Hazards - Mechanical

**Physical injury:****DANGER !****Unconsciousness and injury through:**

- crushing, shearing, cutting and twisting
- drawing in, ramming, piercing and rubbing
- slipping, stumbling and falling

**Causes:**

- crushing-, shearing- and twisting
- parts rupturing or bursting

**Safety options:**

- keep floor, equipment and machinery clean
- eliminate leakages
- observe the required safety distance

### 0.4.2 Hazards - Electrical

Work on electrical apparatus or machinery may only be performed by qualified electricians or persons under the supervision and guidance of qualified electricians, in accordance with predefined electro-technical regulations.

**Physical injury:****DANGER !****Death from electrical shock, injury and burns through:**

- contact
- faulty insulation
- faulty servicing or repair work
- short circuit

**Causes:**

- contact with, touching or standing too close to uninsulated power and live parts
- use of uninsulated tools
- exposed electricity supply terminals following insulation failure
- inadequate safety checks following repair work
- incorrect fusing

**Safety options:**

- isolate machinery and equipment designated for repair or service work before commencing such work
- first check isolated parts for voltage
- regularly check electrical fittings
- replace loose or damaged cables immediately
- always replace blown fuses with fuses of the correct type/value
- avoid contact with or touching live terminals
- only use insulated tools

**0.4.3 Sound pressure level**

Tests on the chain hoist sound level are performed at a range of 1, 2, 4, 8 and 16 metres from the centre of the chain hoist motor to the measuring device.

Measurement of SPL according to DIN 45 635.

The SPL was measured:

- a) during operation of electric chain hoists on factory site
- b) during open-air operation

Table 0-1 Sound level

Types	Measuring distance	1 m	2 m	4 m	8 m	16 m
	Measurement type	dBA				
GPM 250	a)	65	62	59	56	53
	b)	65	59	53	47	41
GPM 250 1 Ph	a)	76	73	70	67	64
	b)	76	70	64	58	52

**0.5 Technical status**

This instruction manual was issued in 2014. It corresponds to directive 2006/42/EG of the European Parliament and council of 17 May 2006.

**0.5.1 Technical data**

0.5.1.1 Model GPM .....Table 0-2, page 17

0.5.1.2 Model GPMH .....Table 0-3, page 17

**0.5.2 Periodic checks**

Each hoist operator should adequately note all checks, maintenance and inspections performed in the log book, and have these confirmed by the competent person in charge.

Incorrect or missing entries will lead to forfeiture of the manufacturer's warranty.

**CAUTION !**

Equipment and cranes are to be checked periodically by a specialist. Primarily visual and functional checks are to be carried out, whereby the state of components with respect to damage, wear, corrosion or any other changes are determined. In addition, safety equipment is assessed for completeness and efficiency. It may be necessary to dismantle the equipment under inspection to correctly assess spare parts.

**CAUTION !**

Suspensions must be inspected over its entire length, including covered or hidden parts.

**CAUTION !**

All periodical inspections should be arranged by the operator.

### 0.5.3 Warranty

- The warranty is void if the installation, operation, testing or maintenance is not carried out according to these instructions
- Troubleshooting and repair under warranty may only be carried out by qualified persons and only after consultation and agreement with the manufacturer / supplier. Any modifications to the product or the use of non-original spare parts will void the warranty

### 0.6 Intended use

The electric chain hoists of the GPM series are lifting equipment for various loads. They can be installed as stationary or mobile units. The electric chain hoists are manufactured in accordance with the latest technical developments and recognised safety standards, and are tested for safe operation by the manufacturer.

Electric chain hoists are approved by various international institutes such as BG and others.

Electric chain hoists of the above series may only be used when in an acceptable technical condition, in accordance with their intended use, by trained personnel in a safe and responsible manner.

The intended use of the electric chain hoists likewise assumes the adherence to the operating, maintenance and servicing prescribed by the manufacturer.

The operational parameters do not include:

- exceeding the defined load capacity
- pulling the load diagonally (see figure 0-5)
- heaving, pulling or dragging the load
- transporting persons
- transporting loads when personnel are underneath
- standing under suspended loads (see figure 0-6)
- transporting excessive loads
- pulling on the control cable
- failing to observe the load hook constantly
- running the chain over edges
- failing to observe the load constantly
- allowing the load to fall due to a slack chain
- use at temperatures below  $-15^{\circ}\text{C}$  or above  $+50^{\circ}\text{C}$
- use in an explosive environment

See also chapter 0.3.

Figure 0-5

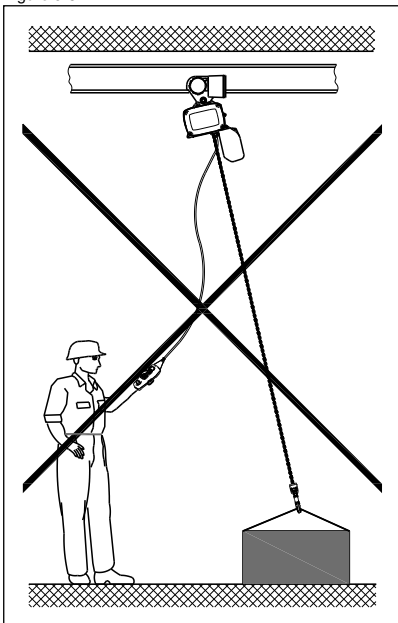
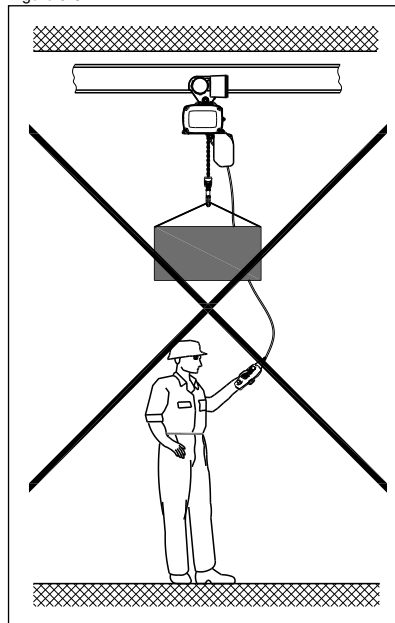

Figure 0-6



Inching operations, ground mooring and driving against the limit stops should be avoided. The manufacturer accepts no liability for damage to equipment and third parties ensuing from such action.

#### 0.6.1 Instructions for using the instruction manual

This instruction manual includes the following chapters:

- |   |                      |   |   |
|---|----------------------|---|---|
| 0 | General instructions | 4 | Measures for achieving safe operating periods |
| 1 | Description          | 5 | Appendix                                      |
| 2 | Start-up             |   |   |
| 3 | Care and maintenance |   |   |

Supplementary to the instruction manual, the following documentation from the operator must be noted:

- Declaration of conformity
- Log book
- Spare parts list(s)
- Circuit diagrams

**Page- and figure numbering:**

The pages are consecutively numbered. Blank pages are not numbered, however are calculated together with the consecutive pages. Figures are numbered consecutively by chapter.

Example:

Figure 3-1 means: in chapter 3, figure 1

## 1 Description

**General:**

The GPM series comprises the following models:  
GPM, GPMH

### 1.1 Operating conditions

**Classification according to application requirements:**

Electric chain hoists and travelling gears are classified according to the following regulations into ISO Groups:

- DIN EN 14492-2
- DIN 15401 (load hook)
- FEM calculation regulations for series lifting equipment (chain drive, motor, full load-life span)
- ISO 4301-1: D (M5) = 1600 h
- Remarks about general revision (see chapter 4)

There is different coefficient data for the ISO Groups that must be adhered to in operation.



**CAUTION !**

The travel trolley must have at least the same load capacity as the electric chain hoist belonging to it.



**NOTE**

The ISO Duty Group registration number of the electric chain hoist can be found on the data plate.

The manufacturer will only guarantee the safety and lasting operation of the electric chain hoist when used for applications that fall within its valid ISO Group coefficient group.

Before the first start-up, the user must estimate according to the features in table 1-1, which of the four types of load is applicable to the use of the electric chain hoist during its whole service life. Table 1-2 shows standard values for the operating conditions of the ISO Groups depending on the type of load and the time of operation.

Ascertaining the correct type of application for an electric chain hoist:

Either the running time or expected type of load can be used as a basis for ascertaining the correct type of application for the electric chain hoist.



**CAUTION !**

Before starting up the electric chain hoist for the first time, it must be determined with which of the load types shown in table 1-1 the electric chain hoist is to operate. Assignment to a load type or a load collective (k) applies for the entire operational life of the equipment and may not be altered for operational safety reasons.

Example 1: Ascertaining permissible running time of the electric chain hoist:

An electric chain hoist of the ISO Group M4 is to be used for medium stress load tasks throughout its entire service life. This corresponds to load type <3 heavy> (see table 1-1). According to the values in table 1-2, the electric chain hoist should not be used for longer than 0.5 - 1 hour per working day.

Example 2: Determining permissible load type:

An electric chain hoist of the ISO Group M5 is to be used for approximately 6 hours per working day, throughout its complete service life. Consequently the electric chain hoist should be operated in accordance with the characteristics of the load type <1 light> (see table 1-1).



Table 1-1 Load collectives

Load type 1 light $k < 0.50$ $k = 0.50$	Load type 2 medium $0.50 < k < 0.63$ $k = 0.63$	Load type 3 heavy $0.63 < k < 0.80$ $k = 0.80$	Load type 4 very heavy $0.80 < k < 1.00$ $k = 1.00$
<p>% of bearing capacity</p> <p>% of running time</p> <p>Full load by way of an exception, however, predominantly low loads</p>	<p>% of bearing capacity</p> <p>% of running time</p> <p>Frequently fully loaded, however continuously lightly loaded</p>	<p>% of bearing capacity</p> <p>% of running time</p> <p>Frequently fully loaded, continuous average loading</p>	<p>% of bearing capacity</p> <p>% of running time</p> <p>Regularly fully loaded</p>

k = Load collective (type of load)

Table 1-2 Operating conditions

ISO Group according to ISO 4301-1	M3	M4	M5	M6	M7
Load collective	Average running time per working day [h]				
1 - light $k < 0.50$	up to 2	2 - 4	4 - 8	8 - 16	over 16
2 - medium $0.50 < k < 0.63$	up to 1	1 - 2	2 - 4	4 - 8	8 - 16
3 - heavy $0.63 < k < 0.80$	up to 0.5	0.5 - 1	1 - 2	2 - 4	4 - 8
4 - very heavy $0.80 < k < 1.00$	up to 0.25	up to 0.5	0.5 - 1	1 - 2	2 - 4

## 1.2 General description

Figure 1-1

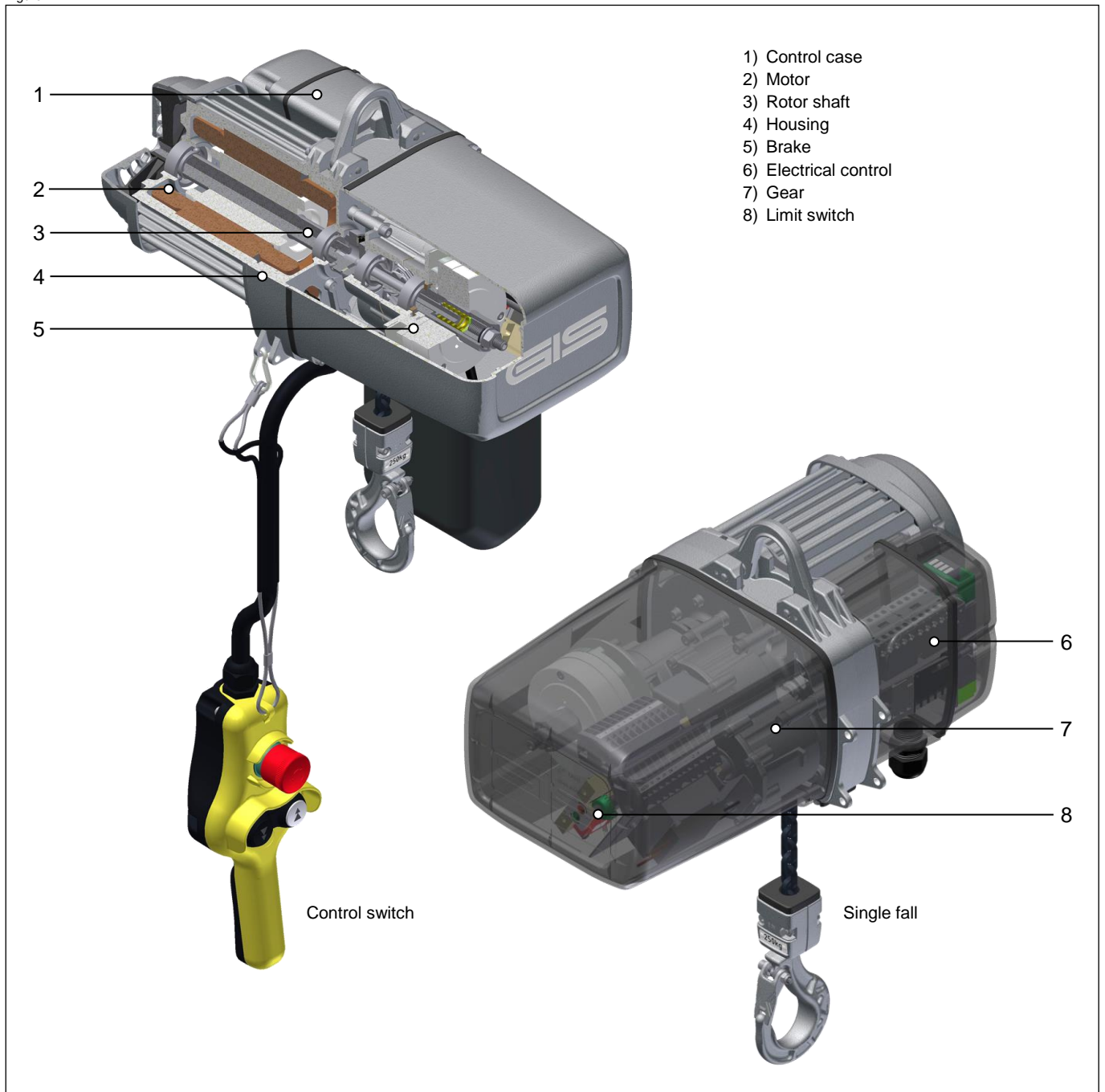

The electric chain hoist meets the requirements of the EC Machinery Directive and the relevant EN and FEM standards. Housing and cover are made of a sturdy aluminium casting. Cooling fins and a ventilator provide optimal cooling of the motor. The chain box can be attached to the compactly constructed housing. A drilled hole is provided for both the power supply cable gland and the control cable. The lugs, or optionally the suspension hooks, are attached to the flange ring. GIS electric chain hoists are driven by asynchronous motors. For two-speed models a pole switching version of the motor is fitted. The braking system consists of a DC-operated spring loaded brake. When there is no current, the pressure spring generates the braking torque. The slipping clutch is built in front of the braking system according to its function. It protects the hoist from overload and takes on the function of an emergency end stop for the highest and lowest hook positions. A gear-type limit switch is fitted to limit the highest and lowest hook position. As an option, emergency stop contacts with positive separation can be retrofitted downstream. Electric chain hoists are fitted with a 42 V contactor control as standard. The emergency stop contactor that is usually installed separates all three mains power phases when the red button is pressed. The high tensile Profile Steel Chain corresponds to grade DAT (8SS) according to DIN EN 818-7. The chain wheel is hardened. The load hook, which complies with DIN 15401, is fitted with a safety latch. The 3-step enclosed spur gears are generally helical. The gears are mounted on roller bearings and run greased. The standard equipment fitted to the electric chain hoist includes a pendant control switch (up/ down with emergency stop).

### 1.3 Special models

Figure 1-2



## 2 Start-up



**DANGER !**

Mechanical adjustments may only be performed by authorised specialists.



**CAUTION !**

Operating staff must carefully read the instruction manual of the electric chain hoist before its initial operation and carry out all checks. Only when safe operation has been established may the device be put into operation. Unauthorised persons may not operate the device or carry out work with it.



**CAUTION !**

The operator must create an inspection log book when start-up the electric chain hoist. The inspection log book is to contain all the technical data and the date of start-up. It provides a record of all servicing and maintenance work.

## 2.1 Transport and assembling

The safety directions for handling loads should be followed (see chapter 0.3) when transporting and assembling the electric chain hoist. Electric chain hoists must be assembled by qualified staff, always bearing in mind the accident prevention directions in chapter 0.2. Before assembly the electric chain hoist must be stored in an enclosed room or covered area. Should the electric chain hoist be destined for operation outdoors, then it is recommended that a protection cover is erected to shield it from the effects of the weather. Wherever possible, the electric chain hoist should be transported in its original packaging. The goods delivered should be checked for completeness and the packaging disposed of in an environmentally sound manner. It is recommended that the electric chain hoist is assembled and connected on-site by our qualified customer service personnel.

## 2.2 Connecting

### 2.2.1 Electrical connection



#### **DANGER !**

Electro-technical adjustments may only be performed by authorised specialists.

The mains connection cable, the mains connection fuse and the main switch for connecting the electric chain hoist to the mains power supply must be installed beforehand by the customer.

A 4-wire cable with a PE protective conductor is needed to provide the power supply for three-phase models. A 3-wire cable with a protective conductor is adequate for single-phase models. The length and cross-section must be appropriate for the power consumption of the electric chain hoist to avoid voltage drop.

- Before connecting the electric chain hoist, check whether the operating voltage and frequency that are specified on the name plate correspond to the available power supply
- Remove the cover from the control case
- Insert connecting cable with M20 x 1.5 screwed cable connection into the lower hole and connect to terminals L1, L2, L3 and PE according to the supplied wiring diagram (see figure 2-1)
- Insert control cable with M20 x 1.5 screwed cable connection through hole in underside of housing and connect to terminals 1, 2, 3, 4 and 10 (see figure 2-2)
- Attach strain relief to housing (see figure 2-3)



#### **CAUTION !**

The control switch must be attached to the strain relief cord and not to the cable.

Figure 2-1

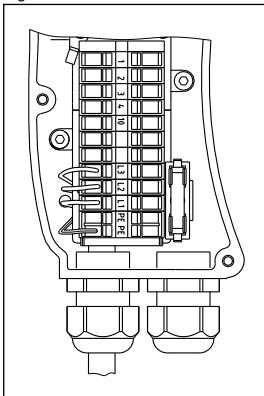

Figure 2-2

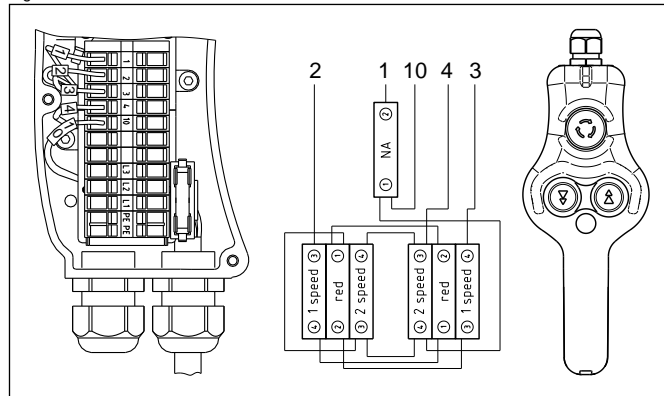
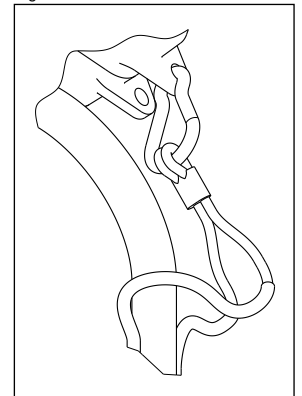

Figure 2-3



#### **DANGER !**

The protective conductor should not carry any power. With the installation of a motor protector, the load plate voltage of the electric chain hoist must be observed.



#### **CAUTION !**

- Checking direction of rotation: If the direction of rotation does not correspond to the button symbols on the control switch, power supply wires L1 and L2 must be swapped round
- Inching operations on single-phase models can cause interference



#### **NOTE**

Open the terminal that is used in accordance with figure 2-4.

Figure 2-4

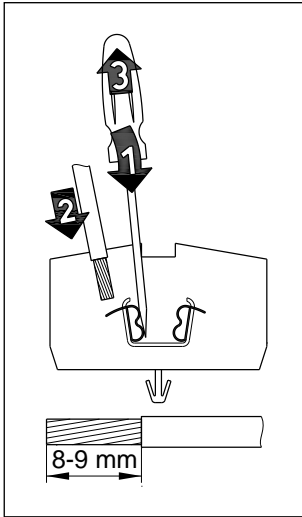
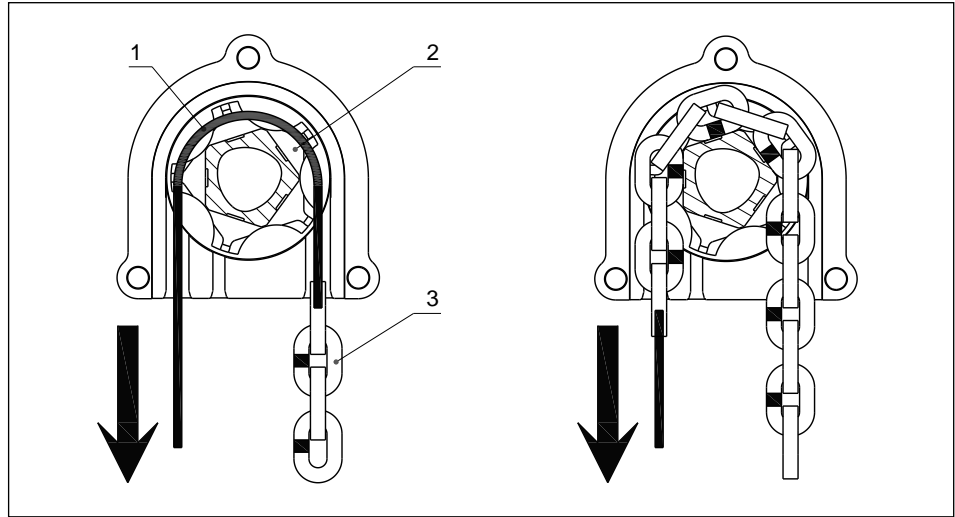

Figure 2-5



## 2.2.2 Load chain



### CAUTION !

- Only use original chains
- Welded seam of the chain links must face inward on the chain wheel (see figure 2-5)
- The gearbox limit switch must be mechanically disabled when pulling in the chain, see chapter 2.2.3

Before start-up and during operation the load chain must be oiled along its full length. Oil must constantly be present on the internal, contacting and rubbing surfaces of the chain links. Lubrication is carried out by submersion or with an oil can, using a creeping gear oil. The end of the chain should be attached to a flexible piece of wire (1) and fed through the chain wheel (2) of the electric chain hoist. Through short switching impulses, the chain (3) will be housed correctly in accordance with figure 2-5. The lifting height must be adjusted such that the hook fittings lie on the ground in the lowest hook position.

**Load hook:** The load hook (1) is connected to the chain with a hook clamp (2). For the power transmission, the mounting of the bolt (3) is important (see figure 2-6).

**Chain end:** The chain end is to be fixed to the housing according to figure 2-7.

The section of chain after the end stop (1) must be adjusted to the height of the chain bucket. The length of the section of chain must be selected so that the end stop lies on the floor of the container when the chain runs into it (see figure 2-7).

Figure 2-6

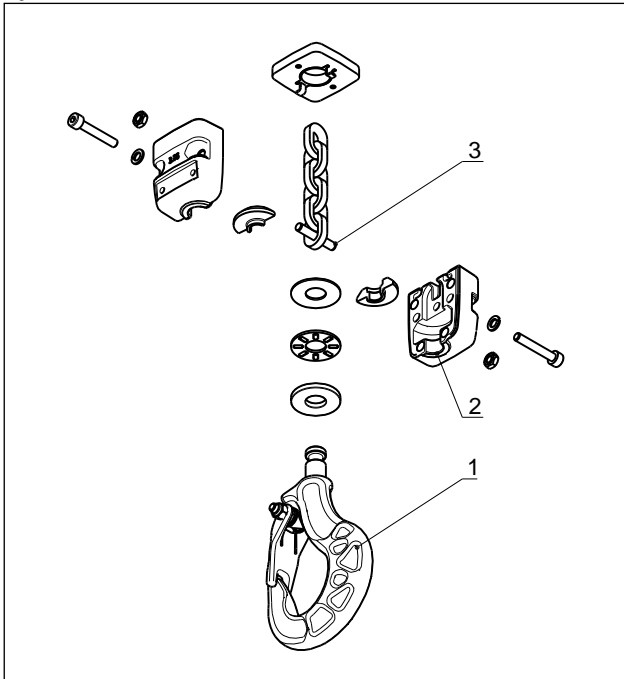
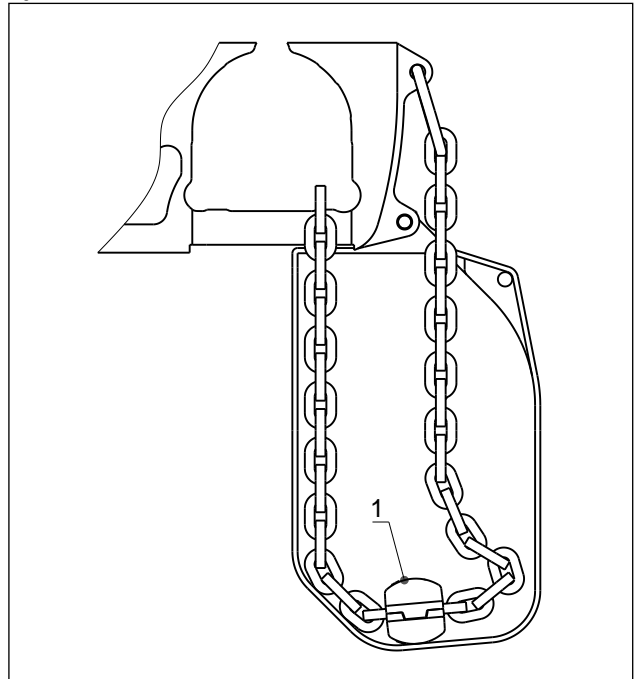

Figure 2-7



### 2.2.3 Limit switch

The electric chain hoist is equipped with a gearbox limit switch as standard. This is also suitable for normal limit switch operation with a high degree of accuracy. The operation of the limit switches (highest and lowest hook position) must be checked during start-up. Three different transmissions are available that are adapted to the lift:

GPM 250		
Transmission	Colour	Single fall lift [m]
i = 1:1	black	14
i = 1:3	yellow	42
i = 1:6	blue	90

#### Description of settings (see figure 2-8):

- Preparing: Loosen the screws (1 + 2), move terminal strip (3) to the side
- Before pulling in the chain or changing the chain, the gearbox limit switch must be mechanically disabled by pressing the rocker (4)
- Pull in the chain
- Bring the hook to its highest position, turn the red control wheel (5, rear) to the cam of the limit switch above (6) (lower hook position turn clockwise, higher hook position anti-clockwise)
- Enable rocker (4) (must engage in the control wheel)
- Bring the hook to its lowest position, press the rocker (4) and turn the green control wheel (7, front) to the cam of the limit switch below (8) (lower hook position turn clockwise, higher hook position anti-clockwise)
- Enable rocker (4) (must engage in the control wheel)



#### CAUTION !

Check the limit switching function: The end stop and the hook fittings must not contact the housing.

Figure 2-8

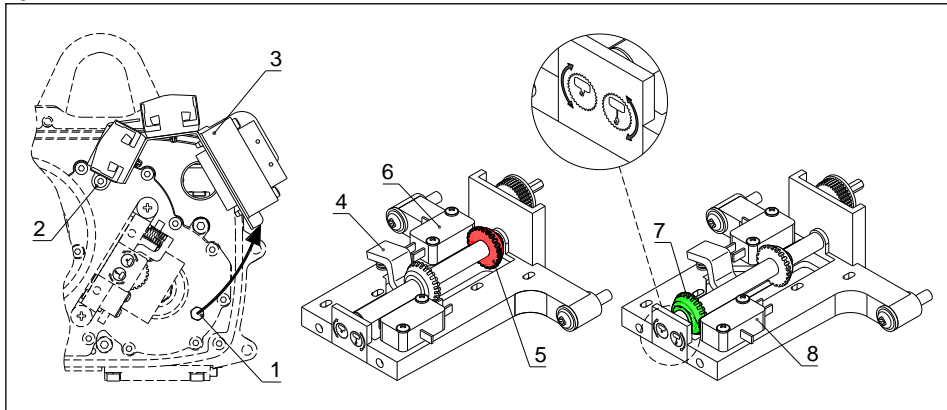
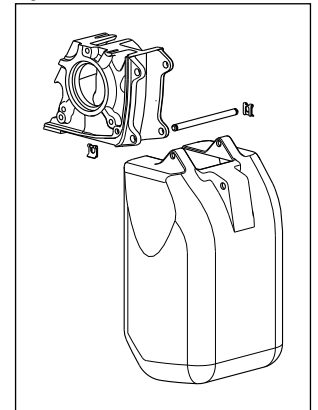

Figure 2-9



### 2.2.4 Chain container

- Move chain out at load side until limit switch is activated
- Attach free end of chain to housing (see chapter 2.2.2)
- Attach chain bucket and allow chain to run in (see figure 2-9)

## 3 Care and maintenance

### 3.1 General guidelines for maintenance and servicing

Operating failures in electric chain hoists affecting the safe operation of the device should be remedied immediately.



#### CAUTION !

Maintenance and repair work on the electric chain hoist may only be carried out by qualified and trained personnel.



#### CAUTION !

If the operator performs maintenance work on an electric chain hoist on his own account, the type of maintenance performed together with the date carried out must be entered in the log book.

Alterations to, as well as modifications and supplements to electric chain hoists which may affect safety must be authorized by the manufacturer in advance. Structural alterations to chain hoists not authorized by the manufacturer exempt the manufacturer from liability in case of damage or accidents. Material warranty claims will only be recognised as valid if exclusively original manufacturer's spare parts are used. We explicitly advise that original parts and accessories not delivered us are also not checked and released by us.

**General:**

Service and maintenance are preventive measures designed to preserve the full functionality of electric chain hoists. Non-compliance with service and maintenance routines can result in reduction in the useful function of and/ or damage to electric chain hoists.

Service and maintenance work should be carried out at the predefined time intervals, in accordance with the instruction manual (table 3-1 and 3-2). During service and maintenance work, general accident prevention directions, special safety directions (chapter 0.3) as well as hazard protection instructions (chapter 0.4) should be followed.

**DANGER !**

Service and maintenance work should only be performed on unloaded electric chain hoists. The main switch must be off. The hook fittings must lie on the ground or on the maintenance platform.

Maintenance work encompasses visual checks and cleaning routines. Service work includes additional functional checks. During the functional checks, all fixing elements and cable clamps must be checked for tightness. Cables must be inspected for dirt, discolouration and scorching.

**CAUTION !**

Used operating materials (oil, grease, etc.) should be safely collected and disposed of in an environmentally friendly manner.

Service and maintenance intervals are defined as follows:

- d..... : daily
- 3 M..... : quarterly
- 12 M..... : annually

The predefined service and maintenance intervals should be reduced when the loading of the electric chain hoist is exceptionally large and when frequently operated in adverse conditions (dust, heat, humidity, steam, etc.).

## 3.2 Care and maintenance

### 3.2.1 Care overview

Table 3-1 Maintenance overview

Term	t	3 M	12 M	Activity	Notes
1. Load chain	X			visual check clean and lubricate as needed	see chapter 2.2.2
2. Lifting gear and suspension	X			check for abnormal noise / sealing	
3. Electric power supply cable	X			visual check	
4. Limit switch	X			function check	see chapter 2.2.3
5. Sealing		X		visual check	
6. Strain relief control cable	X			visual check	

### 3.2.2 Maintenance overview

Table 3-2 Service overview

Term	t	3 M	12 M	Activity	Notes
1. Load chain		X	X	lubricate measure wear	see chapter 2.2.2 / 3.2.4
2. Braking system	X		X	function check with load	see chapter 3.2.3
3. Electrical equipment			X	function check	
4. Fixing screws on suspension parts and load hook with accessories			X	check for cracks check screw movement	see chapter 3.2.8
5. Limit switch			X	check switching elements	see chapter 2.2.3
6. Slipping clutch			X	function check	see chapter 3.2.7

### 3.2.3 Braking system

The spring-loaded brake is a solenoid operated single disk brake with two friction surfaces. The braking force is applied by compression springs. The braking torque is generated when no current is applied. The ventilation is electromagnetic. The brake operates with DC current.

The brake must be able to hold the nominal load in power free mode without any problems.

**CAUTION !**

The brake coil voltage must be the same as the operating voltage.

**NOTE**

The brake has no air gap adjustment. If the air gap (a max., table 3-3 and figure 3-1) reaches maximal value, the brake pad needs changing.

Table 3-3 Air gap

		GPM 250
Air gap (a)	[mm]	0.4 <sup>+0.15</sup> <sub>0</sub>
Air gap (a <sub>max</sub> )	[mm]	0.7
Torque value	[Nm]	3

Figure 3-1

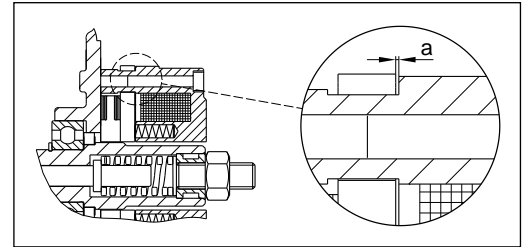

### 3.2.4 Load chain

The load chain should be periodically checked for abrasion. The check is based on three measurements: see permissible wear and tear values (table 3-4) and measuring points (figure 3-2).



**CAUTION !**

The chain should be replaced when the measurements exceed or fall short of those defined in the table. The chain wheel and chain guide should be checked for wear at the same time and, where necessary, be replaced. Only use original chains. The chain links should not be welded.

The new chain is installed in accordance with chapter 2.2.2.



**NOTE**

For ease of installation, the old chain and new chain can be connected by a piece of flexible wire.

Table 3-4 Wear factors load chain

		GPM 250
Chain type d x t	[mm]	3.75 x 10.75
Tolerances in accordance with: DIN 685, part 5 DIN EN 818-7	[mm]	120.6
1. Measurement over 11 chain links; a = 11t	[mm]	11.3
2. Measurement over 1 chain link 1t	[mm]	11.3
3. Measurement of the chain link diameter $dm = \frac{d1 + d2}{2}$ ; (dm min. = 0.9 x d)	[mm]	3.4

Figure 3-2

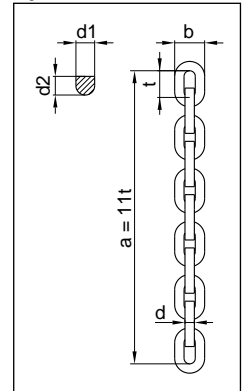

### 3.2.5 Limit stop



**CAUTION !**

A damaged buffer plate, underneath the housing, must be replaced.

Check screw fittings at the limit stop and clamp and tighten with the correct torque if necessary. For coefficient data see chapter 3.2.8.

### 3.2.6 Gearing

The gearing has continuous lubrication.

Lubricant.....: Strub N1424

Mixable and compatible with all other brands of grease of a comparable type.  
(DIN 51502: GP OM-20)

Lubricant quantity.....: GPM 250: 50 ml

### 3.2.7 Slipping clutch

The slipping clutch is set at the works to 125% and reliably prevents overloading of the chain hoist (the power limiting factor according to DIN EN 14492-2 is  $\Phi_{DAL} = 1.4$ ). The coating is wear resistant.



**CAUTION !**

Adjustment and testing of the slip clutch may only be carried out by authorized personnel and must be recorded in the log book. If the nominal load is no longer lifted, or there is delay in achieving the lifting speed, the slipping clutch must be adjusted.

### 3.2.8 Suspension parts

All statically loaded parts are considered to be suspension parts. The bearing surfaces of the slewing suspension parts must be periodically greased. Torque values for screws of property class 8.8 according to DIN ISO 898:

M 4	M 5
3.3 Nm	6.5 Nm

### 3.3 Ordering spare parts

Information on how to order spare parts can be found on page 3.

## 4 Measures for achieving safe operating periods

The statutory and health requirements of the EU regulations stipulate that specific dangers which may arise from fatigue or ageing must be prevented.

Accordingly, operators of standard hoist gear are obliged to determine the actual utilization. The actual utilization period is determined and recorded as part of the annual inspection by customer service engineers. A general overhaul must be carried out when the theoretical utilization limit is reached, or after no more than 10 years. All checking and the general overhaul itself must be arranged by the operator of the hoist gear. The following theoretical utilization periods apply to electric chain hoists that are categorized according to ISO 4301-1 (converted into full-load hours):

M3	M4	M5	M6	M7
400 h	800 h	1600 h	3200 h	6300 h

### 4.1 Determining the actual period of use S

The actual utilization period depends on the daily operating time and the load collective.

Running time is determined from information provided by the operator or recorded using a meter that counts the number of operating hours. The load collective is determined according to table 1-1, page 9. With these values, the yearly period of use can be found in table 4-1.

If an operating data acquisition system (BDE) is used, the actual utilization can be read out directly by our experts during the annual inspection.



#### CAUTION !

The values periodically calculated or read-off must be recorded in the log book.

### 4.2 General overhaul

On reaching the theoretical service life (no later than 10 years for recording without BDE), a general overhaul should be performed. This enables the equipment to continue operating safely for a further period of utilization (service life). Components must be checked or replaced according to table 4-2. The checking and release for the further usage must be done by a specialist company authorised by the manufacturer or by the manufacturer himself.

The inspector determines: – what theoretical new usage is possible  
– the max. time period to the next general overhaul

This data should be recorded in the log book.

Table 4-1 Annual service life

Utilization per day [h]	<= 0.25 (0.16)	<= 0.50 (0.32)	<= 1.0 (0.64)	<= 2.0 (1.28)	<= 4.0 (2.56)	<= 8.0 (5.12)	<= 16.0 (10.24)	> 16.0 (20.48)
Load collective	Annual operating life [h]							
k = 0.50	6	12	24	48	96	192	384	768
k = 0.63	12	24	48	96	192	384	768	1536
k = 0.80	24	48	96	192	384	768	1536	3072
k = 1.00	48	96	192	384	768	1536	3072	6144

Table 4-2 General overhaul

Check components GPM model all types	for wear *	Replace
Brake	x	
Motor shaft	x	
Gear teeth		x
Antifriction bearing		x
Washers		x
Chain	x **	
Chain wheel, chain guide	x	
Suspension	x	
Load hook		x
Travelling gear, running wheel	x	
Contact, limit switch	x	

\* replace if worn

\*\* replace at the latest in general overhaul



## 5 Appendix

### 5.1 Technical data

Table 0-2 Technical data GPM

ISO (FEM) classification	M5 (2m) 240 s/h 40% duty	M6 (3m) 300 s/h 50% duty	M7 (4m) 360 s/h 60% duty	Lifting speed 50 Hz	Lifting speed 60 Hz	Motor type	No. of chain falls	Dead weight 3 m lift	Mains fuse (delayed)
Types	Capacity [kg]			[m/min]	[m/min]			[kg]	[A]
GPM 250/1NF	250	200	160	8/2	9.6/2.4	71 B 8/2	1	17	6
GPM 250/1SF	125	100	80	16/4	19.2/4.8	71 B 8/2	1	17	6
GPM 250/1NL 1Ph	250	200	160	4	4.8	71 A 4	1	17	10
GPM 250/1N 1Ph	125	100	80	8	9.6	71 A 4	1	17	10

Table 0-3 Technical data GPMH

ISO (FEM) classification	M5 (2m) 240 s/h 40% duty	M6 (3m) 300 s/h 50% duty	M7 (4m) 360 s/h 60% duty	Lifting speed 50 Hz	Lifting speed 60 Hz	Motor type	No. of chain falls	Dead weight 3 m lift	Mains fuse (delayed)
Types	Capacity [kg]			[m/min]	[m/min]			[kg]	[A]
GPMH 250/NF	250	200	160	8/2	9.6/2.4	71 B 8/2	1	20	6
GPMH 250/SF	125	100	80	16/4	19.2/4.8	71 B 8/2	1	20	6

### 5.2 Electrical parameters

Table 0-4 Electrical parameters GPM, 3 Ph

Types	Motor type	No. of poles	P <sub>N</sub> [kW]	n <sub>N</sub> [1/min]	min. / max. currents and start-up current									
					3 x 400 V, 50 Hz					3 x 230 V, 50 Hz				
					I <sub>N 380</sub> [A]	I <sub>N 415</sub> [A]	I <sub>max.</sub> [A]	I <sub>A</sub> /I <sub>N 415</sub>	cos φ <sub>N</sub>	I <sub>N 220</sub> [A]	I <sub>N 240</sub> [A]	I <sub>max.</sub> [A]	I <sub>A</sub> /I <sub>N 240</sub>	cos φ <sub>N</sub>
GPM 250	71 B 8/2	8	0.10	675	1.2	1.4	1.6	1.45	0.56	2.2	2.4	2.7	1.45	0.56
		2	0.37	2825	1.6	2.1	2.4	2.75	0.63	2.6	3.2	3.8	2.75	0.63

Table 0-5 Electrical parameters GPM, 3 Ph

Types	Motor type	No. of poles	P <sub>N</sub> [kW]	n <sub>N</sub> [1/min]	min. / max. currents and start-up current									
					3 x 460 V, 60 Hz									
					I <sub>N 460</sub> [A]	I <sub>N 480</sub> [A]	I <sub>max.</sub> [A]	I <sub>A</sub> /I <sub>N 480</sub>	cos φ <sub>N</sub>					
GPM 250	71 B 8/2	8	0.11	825	1.2	1.3	1.6	1.45	0.55					
		2	0.44	3425	1.6	1.8	2.4	2.75	0.62					

Table 0-6 Electrical parameters GPM, 3 Ph

Types	Motor type	No. of poles	P <sub>N</sub> [kW]	n <sub>N</sub> [1/min]	min. / max. currents and start-up current									
					3 x 230 V, 60 Hz					3 x 575 V, 60 Hz				
					I <sub>N 220</sub> [A]	I <sub>N 240</sub> [A]	I <sub>max.</sub> [A]	I <sub>A</sub> /I <sub>N 240</sub>	cos φ <sub>N</sub>	I <sub>N 575</sub> [A]		I <sub>max.</sub> [A]	I <sub>A</sub> /I <sub>N 575</sub>	cos φ <sub>N</sub>
GPM 250	71 B 8/2	8	0.11	825	2.6	3.2	3.5	1.45	0.55	0.9		1.0	1.35	0.65
		2	0.44	3425	3.1	3.8	4.2	2.75	0.62	1.0		1.4	3.5	0.63

Table 0-7 Electrical parameters GPM, 1 Ph

Types	Motor type	No. of poles	P <sub>N</sub> [kW]	n <sub>N</sub> [1/min]	min. / max. currents and start-up current									
					1 x 115 V, 50 Hz					1 x 230 V, 50 Hz				
					I <sub>N 115</sub> [A]		I <sub>max.</sub> [A]	I <sub>A</sub> /I <sub>N 115</sub>	cos φ <sub>N</sub>	I <sub>N 230</sub> [A]		I <sub>max.</sub> [A]	I <sub>A</sub> /I <sub>N 230</sub>	cos φ <sub>N</sub>
GPM 250	71 A 4	4	0.25	1385	5.7		5.9	1.65	0.55	3.0		3.2	1.95	0.55

Table 0-8 Electrical parameters GPM, 1 Ph

Types	Motor type	No. of poles	P <sub>N</sub> [kW]	n <sub>N</sub> [1/min]	min. / max. currents and start-up current									
					1 x 115 V, 60 Hz					1 x 230 V, 60 Hz				
					I <sub>N 115</sub> [A]		I <sub>max.</sub> [A]	I <sub>A</sub> /I <sub>N 115</sub>	cos φ <sub>N</sub>	I <sub>N 230</sub> [A]		I <sub>max.</sub> [A]	I <sub>A</sub> /I <sub>N 230</sub>	cos φ <sub>N</sub>
GPM 250	71 A 4	4	0.30	1685	9.2		9.5	1.65	0.54	3.4		3.7	1.95	0.54



## EC DECLARATION OF CONFORMITY

Declaration for a machinery according to the EU directives 2006/42/EC, Annex II A, 2004/108/EC, Annex I and 2006/95/EC, Annex III

Hereby we,

**GIS AG, Swiss Lifting Solutions, Luzernerstrasse 50, CH-6247 Schötz**

declare that the machinery



**GIS electric chain hoist, series  
with a load capacity of**

**GPM  
80 kg - 250 kg**

developed for lifting and lowering loads, is, in standard production and from the 2014 model year, inclusive of load control, meets the essential requirements of the following EC directives, as applicable to the scope of the delivery:

EC Machinery Directive	2006/42/EC
EC Directive on Electromagnetic Compatibility	2004/108/EC
EC Low Voltage Directive	2006/95/EC

### Harmonized standards applied:

ISO 2374	Lifting appliances; Range of maximum capacities for basic models
DIN EN 818-7	Short link chain for lifting purposes; Part 7: Grade T
DIN EN ISO 13849-1	Safety-related parts of control systems; Part 1: General principles for design
DIN EN 14492-2	Cranes, power driven winches and hoists; Part 2: Power driven hoists
DIN EN 60204-32	Electrical equipment of machines; Part 32: Requirements for hoisting machines

### Standards and technical specifications applied:

FEM 9.751	Power driven series hoist mechanisms; Safety
FEM 9.755	Measure for achieving safe working periods

### Authorized to compile relevant technical documentation:

Mr. Pius Engel, GIS AG, Luzernerstrasse 50, CH-6247 Schötz

Schötz, 28.04.2014

**GIS AG**

I. Muri  
Director

E. Widmer  
Sales Manager

The completion, installation and start-up as per instruction manual is documented in the log book.



## EC DECLARATION OF INCORPORATION

Declaration for the incorporation of a partly completed machinery according to the EU directives 2006/42/EC, Annex II B, 2004/108/EC, Annex I and 2006/95/EC, Annex III

Hereby we,

**GIS AG, Swiss Lifting Solutions, Luzernerstrasse 50, CH-6247 Schötz**

declare that the partly completed machinery



**GIS electric chain hoist, series  
with a load capacity of**

**GPM  
80 kg - 250 kg**

developed for lifting and lowering loads, is, in standard production and from the 2014 model year, inclusive of load control, intended for installation in machinery and meets the essential requirements of the following EC directives, as applicable to the scope of the delivery:

EC Machinery Directive	2006/42/EC
EC Directive on Electromagnetic Compatibility	2004/108/EC
EC Low Voltage Directive	2006/95/EC

We also declare that the technical documentation has been compiled in accordance with Annex VII, Part B of Directive 2006/42/EC. We undertake to submit the specific documents relating to the lifting device to national authorities on receipt of a reasonable request. The information will be supplied by electronic means.

### Harmonized standards applied:

ISO 2374	Lifting appliances; Range of maximum capacities for basic models
DIN EN 818-7	Short link chain for lifting purposes; Part 7: Grade T
DIN EN ISO 13849-1	Safety-related parts of control systems; Part 1: General principles for design
DIN EN 14492-2	Cranes, power driven winches and hoists; Part 2: Power driven hoists
DIN EN 60204-32	Electrical equipment of machines; Part 32: Requirements for hoisting machines

### Standards and technical specifications applied:

FEM 9.751	Power driven series hoist mechanisms; Safety
FEM 9.755	Measure for achieving safe working periods

**This declaration only refers to the lifting device. A start up is prohibited until its proven that the crane where the lifting device is built in corresponds with the above EC directives.**

**Authorized to compile relevant technical documentation:**  
Mr. Pius Engel, GIS AG, Luzernerstrasse 50, CH-6247 Schötz

Schötz, 28.04.2014

**GIS AG**

I. Muri  
Director

E. Widmer  
Sales Manager

The completion, installation and start-up as per instruction manual is documented in the log book.